

## SECTION 4

### SPECIFICATIONS FOR WATER MAINS AND WATER SERVICES

#### 4.01 DESCRIPTION OF WORK

The work shall consist of furnishing and installing water main of the specified size or sizes at the depths shown on the plans or specified herein, and furnishing all fittings and joint material, labor, materials, tools, and equipment for receiving, unloading, transporting, laying, testing, and disinfecting of water pipe and fittings. The Contractor shall furnish all hydrants, valves, valve boxes and other necessary accessories to complete the pipe work as shown on the plans and specified herein.

#### 4.02 MATERIALS

All materials furnished by the Contractor shall conform to the specifications which follow. Where reference specifications are mentioned the current edition or latest issue shall be used.

##### 4.02.01 Pipe

##### 4.02.01.01 Ductile Iron Pipe

Ductile iron pipe shall conform to the requirements of AWWA C-151 (ANSI A21.51). Ductile iron pipe shall be Class 52 unless otherwise specified. Eight (8) inch is the minimum size.

All pipe and fittings shall have a cement mortar lining conforming to the requirements of AWWA C-104 (ANSI A21.4). Seal coat shall have NSF61 approval for use with potable water.

Unless otherwise specified, all pipe joints shall be rubber gasket joints conforming to the requirements of AWWA C-111 (ANSI A21.11) for bolted mechanical joints or push-on joints. Joints on fittings shall be bolted mechanical joints.

When laying pipe in corrosive type soils the pipe shall be encased in a seamless polyethylene tube, in accordance with AWWA C-105 (ANSI A21.5) 8 mills minimum thickness. The ends of adjacent sections of polyethylene tubing shall be overlapped a minimum of one (1) foot, and the joint taped or otherwise secured to prevent displacement during backfill operations.

#### 4.02.01.02 Other Materials

Ductile Iron pipe shall be the only approved pipe material for water main, unless the Township approves a change in material in writing.

In some cases (i.e. areas that require direction drilling) the Township may consider other materials. Requests for pipe material changes must be submitted to the Township in writing. The Township reserves the right to approve or reject any such requests.

#### 4.02.01.03 Fittings

All fittings shall be ductile iron in accordance with AWWA C-153 (ANSI A21.53). Fittings twenty four (24) inches in diameter and smaller shall have a minimum pressure rating of 350 psi., fittings larger than twenty four (24) inches in diameter shall have a minimum pressure rating of 250 psi.

#### 4.02.02 Valves

##### 4.02.02.01 Resilient Seated Gate Valves

All resilient seated gate valves shall be ductile iron and conform to AWWA C-509, or AWWA C-515, Standards for Gate Valves for Water and Sewerage Systems. The valves shall be fully bronze mounted and shall be furnished with O-ring packing. The direction of the opening shall be to the right. Stainless steel bolts and nuts shall be installed on all valves.

Valves shall be Traverse City Iron Works, East Jordan Iron Works, Clow Corporation R/W Resilient Wedge, Waterous Resilient wedge, U.S. Pipe Metroseal 250 or equal.

All valves 20" and larger shall be equipped with totally enclosed worm gear operator, unless otherwise approved by the Township.

##### 4.02.02.02 Tapping Sleeves

Tapping sleeves shall be Ford stainless steel tapping sleeves style FTSC or approved equal. When tapping a PVC main, a cast iron tapping sleeve will be required.

##### 4.02.02.03 Butterfly Valves (When approved by the Township)

All butterfly valves shall conform to AWWA C-504, Standard for Rubber Seated Butterfly Valves. Valves shall be Class 150-B and shall have a "short body" form. Valves suitable for buried service will be acceptable without a manhole. Valves shall be constructed of material suitable for handling water. Shaft seals shall be replaceable without removing the valve shaft. Valves shall be equipped with totally enclosed worm gear operators conforming to AWWA C-504.

4.02.03 Hydrants

Fire hydrants shall conform to AWWA C-502, Standard for Dry Barrel Fire Hydrants. The six (6) inch mechanical joint inlet shall be located five feet six inches (5'6") below the ground. Hydrants shall be installed so that the center of the pumper nozzle is twenty one (21) inches above the finished grade at the hydrant (approximately 27" above the centerline of the road). Access culverts (where required) shall be installed. Joint materials shall conform to those previously specified under ductile iron joints.

Threads on the hydrant nozzles and the size of the operating nut shall conform to the Holland Charter Township Standards. Nuts and bolts shall be stainless steel. The hydrants shall open right or clockwise. Hydrants shall be furnished with a breakable stem and flange. The pumper connection shall be four and one-half (4 1/2) inches and there shall be two, two and one-half (2 1/2) inch nozzles. The hydrants shall be Traverse City Iron Works, East Jordan Iron Works 5BR with liner, or approved equal. The weep holes shall be ordered plugged, unless otherwise directed by the Township.

4.02.04 Valve Boxes

Valve boxes shall be cast iron screw type, three sectional, adjustable with round bases, with an overall length sufficient to permit the tops to be set flush with the established pavement or ground surface. The box shall be provided with a cast iron lid or cover and marked with the word "WATER". The valve boxes shall be designed to withstand heavy traffic.

Valve nut extensions shall be supplied at no additional cost to the Owner when the height of the valve box exceeds the Township's equipment. The Township uses 8 foot long valve wrenches. When valve nut extensions are provided, they shall be permanently affixed to the valve nut with a non-corrosive device such as a bolt or pin and cotter key; set screws will not be approved.

**4.03 WATER SERVICES**

Water services in the Holland area are installed in accordance with the following specifications.

4.03.01 Service (Maintenance) Areas in the Holland Area (Different service areas require different materials)

A. By Holland Charter Township

1. Holland Charter Township except that portion lying south of Lake Macatawa and Black River (Federal District, Adams Street, etc.).
2. Park Township lying north of Lake Macatawa (Waukazoo Woods area) except that portion connected to the Federal Pipeline (30" diameter south of Perry Street).

3. Zeeland Charter Township except that portion connected to the City of Zeeland which shall be in accordance with the City of Zeeland standards.

B. By City of Holland

1. Entire City
2. Laketown Township
3. Holland Charter Township lying south of Lake Macatawa and Black River (Federal District, Adams Street, etc.)
4. Park Township
  - a. Lying south of Lake Macatawa
  - b. That portion lying north of Lake Macatawa which is connected to the Federal Pipeline (30" diameter south of Perry Street)

4.03.02 Material Specifications

A. HOLLAND CHARTER TOWNSHIP SERVICE AREA:

1. Corporation Stops

Ford	F - 1000
McDonald	4701-22
2. Curb Stops (Compression Fittings, Threaded Top)

Ford	B - 44-444M & B44-666M
McDonald	6104-22
3. Curb Boxes (No Rods are Required)

Minneapolis Pattern (1-1/4")	
Ford EM 2-55-56	
McDonald 5614 & 5615	
4. Pipe

Type K Copper, Annealed, Seamless, ASTM B-88.
---
5. Service Saddles (Clamps)

Same as City of Holland
-------------------------

\* Including that portion of Park Township lying north of Lake Macatawa (includes Federal pipeline district).

B. CITY OF HOLLAND SERVICE AREA:

1. Corporation Stops (Compression Fitting)

Mueller	P-25008 – all sizes
Ford	F - 1000

Corporation Stops shall be inserted directly into the pipe or service clamp, saddle or coupling at a 45° angle with the horizontal

2. Curb Stops (Compression Fitting)

Mueller	P-25209
Ford	B 44-444 & B44-666, B44-777

3. Curb Boxes (No Rods are Required)

Style 95-E Buffalo Box (Case Iron) with arch pattern and 2-1/2" minimum shaft diameter  
Similar to Mueller H-10350, EJIW, Tyler Foundry

4. Pipe

Type K Copper, Annealed, Seamless ASTM B-88

5. Service Saddles (Clamps) where required similar to Mueller Series H - 1600 (Bronze) or Ford 101S or 202S (Stainless Steel)

\* All that portion of Park Township lying north of Lake Macatawa to be the same as Holland Charter Township.

4.03.03 Installation

A. Tapping - Tapping of the mains shall be made under pressure with a tapping machine similar to Hays No. B-1, or Mueller B-100. Drilling through service clamps, saddles or welded couplings shall be performed with a machine similar to Mueller D-5.

B. Pavement Crossing - Service lines shall be jacked or bored across pavements. No pavement shall be cut or removed without permission by the Township and the Road Commission in which the service is located.

C. Cover - All services shall be installed with a *minimum* earth cover of five (5) feet, *without exception*. In no case shall the maximum earth cover exceed seven (7) feet.

- D. Water Service Replacement – When water services are replaced to the curb box as part of the project or when damaged by the Contractor, the Contractor shall make sure that the curb boxes are cleaned and properly adjusted in accordance with Township standards. If the curb box is damaged by the Contractor, the Contractor shall replace the curb box at the Contractor’s expense.

4.03.04 Curb Box Locations

- A. Holland Charter Township service area within right-of-way six (6) inches off property line.
- B. City of Holland service area within right-of-way, seven (7) feet off the property line. Except Park Township, north side of Lake Macatawa to be within right-of-way six (6) inches off property line.
- C. Within easements the curb box shall be set within six inches (6”) of the edge of easement or as designated by the Township.

Note: The curb box is where the change of ownership takes place.

4.03.05 Surface Restoration

The cost of restoration required for water services will be considered incidental.

4.03.06 Dewatering

All taps must be made in a dry trench. The cost of dewatering will be considered incidental.

4.03.07 Polywrap/Coating Repairs

All disturbed polywrap/coatings shall be repaired/replaced to provide the required protection to the mainline watermain.

4.03.08 Water Services within the Public Right-of-Way/Easements-General

After the water main is tested and approved, water services shall be installed for all existing houses or buildings unless otherwise indicated.

**Connection and use:** Connection to the water supply system and use of the water supply system is governed by Section 34 of the Holland Charter Township Code. See this Code for regulations governing use of the water supply system and penalties for violation of the Code.

Services through 2.0” - within public right-of-way of Easements.

1. Installation:

Option 1. The water service will be installed by or on behalf of the Township and will be owned and maintained by the Township.

Option 2. The water service will be installed by a developer in conjunction with a watermain extension and will be turned over to the Township for ownership and maintenance upon satisfactory completion and inspection.

2. Inspection:

The Township must inspect all water services under pressure prior to backfill.

3. Tap Location:

Locations for taps will be determined by the Township. For new developments this will be at the center of the lot. All water services will be installed perpendicular to the watermain unless special circumstances warrant the Township to authorize differently.

4. Tapping Method:

The method of tapping will be determined by the Township (direct, saddle, welded, etc.) and will be in accordance with sound engineering practices. All services must be inspected by the Township or an authorized representative.

4.03.09 Water Services on Private Property-General (Also see the Standard “Rules and Regulations”)

**Application for connection:** Application forms and permits for connection are available at the Township office. These forms will provide for payment of the connection fees at the time request is made for service.

A. Services through 2.0” - Private Portion:

1. Permits:

Permits for installation must be secured from the Township prior to the commencement of any installation.

2. Installation:

All water services must be buried between 5 and 7 feet deep. Water services will meet the same specifications as the public portion.

3. Inspection:

The Township must inspect all water services under pressure prior to backfill.

4. Acceptable Material Allowed:

Type K Copper, annealed, seamless, ASTM B-88, unless otherwise approved by the Township in writing.

B. Services 4.0” and larger (Fire Lines):

1. Permits:

Permits for installation must be secured prior to the commencement of any installation. Forms for the permits will be provided by the Township and will detail procedures for obtaining the permit.

2. Installation:

The customer shall construct, own and maintain the water line at his expense in its entirety.

3. Inspections/Testing:

Inspections, pressure testing, and bacteria sampling must be done in accordance with the Township mainline specifications.

4. Acceptable Materials Allowed:

All services must be of Class 52 (or greater) cement-lined Ductile Iron Pipe. All construction materials must meet the specifications for watermains.

5. Valves:

A valve must be installed at the point the water service is connected to the Township watermain.

6. Tapping Method:

Tapping sleeves shall be Ford stainless steel tapping sleeves style FTSC or approved equal. Cast iron tapping sleeves will be required on PVC pipe.

4.03.10 Water Service Size, Tapping, Meters-General

A. Water Service Size:

1. Single and two-family residences - minimum 1.0” service.
2. Multi-family, commercial and industrial - minimum 1.5” service.



B. Taps:

If the service has not been pre-tapped, the Township contractor will bring the water service connection to the road right-of-way line. If the water service pipe has been installed out to the road prior to this, the Township contractor will connect the line to the tap provided sufficient pipe has been provided. If the tap is to be made before the line to the house is installed, the homeowner or plumber must mark the tap location with a stake.

C. Meters and remotes:

The homeowner or plumber is responsible for the installation of the water meter. Access to the meter must be maintained. Township personnel will install a remote reader to the outside of the structure with a wire running to the meter.

D. Inspections:

All water service installations must be inspected by the Township. Water inspections can be scheduled by calling the Township Maintenance Building at (616) 396-1891 from 7:30 a.m. to 8:00 a.m. each weekday morning. A permit number is required to schedule an inspection.

E. Permits:

Installation permits must be secured prior to the commencement of any construction.

Water services larger than two (2) inches shall conform to the Watermain Specifications.

F. Installation Requirements:

All connections and services must meet the requirements of the Michigan State Plumbing Code and the State of Michigan Department of Environmental Quality (MDEQ) Administrative Rules.

G. Meter/Service Sizes:

Meter and service sizes must be approved by the Township as suitable for the proposed application.

The following service sizes will be allowed: 1.0", 1.5", 2.0", 4.0", 6.0", 8.0", 12.0" and larger. Exceptions to these sizes can be made when the Township determines necessary.

The Township reserves the right to refuse or limit water service when service could overburden the system.

H. Cross Connections:

All connections must meet the requirements of the Holland Charter Township Cross Connection Rules.

I. Fire Hydrants:

Fire hydrants will not be installed on private fire lines. Exceptions may be authorized by the Township on certain high pressure systems when standard hydrants are not used.

J. Special Materials:

The Township reserves the right to require special materials, bedding, and/or construction methods when conditions warrant.

K. Availability:

Water service will be deemed available when the water main lies in a right-of-way or easement adjacent to the property being served.

L. All water services will serve one building only. Exceptions may be made if authorized by the Township for certain complexes and then only after the water is metered.

4.03.11 Meters

A. Installation:

All meters must be installed at the expense of the customer.

All meters must be located at the point of the water service entrance into the building.

Meters must be installed horizontal and according to the manufacturers specifications.

Valves must be installed immediately upstream and downstream of each meter.

Meters may not be installed in pits.

Meter by-passes will not be permitted without Holland Charter Township's Water and Sewer Department approval (or Holland Board of Public Works when in their service area).

B. Accessibility:

All meters must be placed in a location readily accessible to Township Personnel.

Crawl space installations must be approved by the Township prior to service installation.

When more than one meter is installed in a building for metering of tenant spaces, piping and meter configurations must be approved prior to installation and separate shut-offs, accessible to the Township, must be provided.

Customers must provide a chaseway (access way) for installation of the remote wire from the water meter to the outside of the building.

C. Protection:

Meters and equipment must be protected from freezing and other damaging elements.

D. Fittings:

All pipe and fittings prior to metering must be Class 52 cement-lined Ductile Iron, copper or brass.

The Water Department may elect to furnish meter horns and inside fittings, the cost of which will be included with the connection fees.

E. Ownership:

All meters shall remain the property of the Township.

All meters shall be furnished by the Township, the cost of which will be passed on to the customer and included in the connection fees.

**4.04 INSPECTION**

4.04.01 Shop Inspection

All materials furnished by the Contractor are subject, at the discretion of the Township to inspection and approval at the Manufacturer's plant. All inspection in the plant of the manufacturer of materials furnished by the Contractor shall be made at the expense of the Township. If the materials are defective, the Contractor shall pay for costs for replacing the defective materials and for inspection , both for installation and visit at the manufacturers plant.

4.04.02 Field Inspection

All pipe and accessories shall be laid, joined, and tested under pressure for defects and leakage in the manner specified herein and in the presence of, and as approved by the Township.

4.04.03 Disposition of Defective Material

All material found during the progress of the work to have cracks, flaws, or other defects shall be rejected by the Township. All defective materials furnished by the Contractor shall be promptly removed by him from the site.

**4.05 RESPONSIBILITY FOR MATERIAL**

4.05.01 Responsibility for Material Furnished by Contractor

The Contractor shall be responsible for all material furnished by him and shall replace at his own expense all such material found defective in manufacture or damaged in handling after delivery by the manufacturer. This shall include the furnishing of all material and labor required for the replacement of installed material discovered prior to the final acceptance of the work.

4.05.02 Responsibility for Safe Storage

The Contractor shall be responsible for the safe storage of material furnished by or to him, and accepted by him, and intended for the work, until it has been incorporated in the completed project. The interior of all pipe, fittings, and other accessories shall be kept free from dirt and foreign matter at all times. Valves and hydrants shall be drained and stored in a manner that will protect them from damage by freezing.

4.05.03 Replacement of Damaged Material

Any material that becomes damaged after acceptance by the Contractor shall be replaced by the Contractor at his own expense.

**4.06 HANDLING OF MATERIAL**

The Contractor shall use care and proper equipment during the unloading and distribution of water main materials on the job site to insure the materials are not damaged.

Pipe and/or fittings shall not be rolled or skidded off the truck beds against previously unloaded materials.

## **4.07 ALIGNMENT AND GRADE**

### **4.07.01 General**

The water main shall be laid and maintained to the required lines and grades with fittings, valves, and hydrants at the required locations and all valve and hydrant stems plumb.

### **4.07.02 Deviations Occasioned by Other Structures**

Whenever obstructions not shown on the plans are encountered during the progress of the work and interfere to such an extent that an alteration in the plans is required, the Township shall have the authority to change the plans and order a deviation from the line and grade or arrange with the Owners of the structures for the removal, relocation, or reconstruction of the obstructions. If the change in plans results in a change in the amount of work by the Contractor, such altered work shall be done by a written field order.

### **4.07.03 Depth of Pipe**

All pipe shall be laid with the top of the pipe a minimum depth of five (5) feet below established street centerline grade, and with a minimum cover of five (5) feet below existing grade at the water main, unless specified otherwise. Generally watermain shall have a minimum depth of six (6) feet of cover below the established street centerline grade when the water main is installed within a County section road or in an area where road improvements such as widening or adding storm sewer are likely in the future. Watermain eight (8) inches and larger shall be laid to a specified grade. Maximum depth of cover to be nine (9) feet.

## **4.08 LAYING**

### **4.08.01 Lowering of Water Main Material Into Trench**

Proper implements, tools, and facilities shall be provided and used by the Contractor for the safe and expedient completion of the work. All pipe fittings, valves, and hydrants shall be carefully lowered into the trench by means of suitable tools or equipment, in such a manner as to prevent damage to water main material and protective coatings and linings. Under no circumstances shall water main materials be dropped or dumped into the trench.

If damage occurs to any pipe, fittings, valves, hydrants, or water main accessories in handling, the damage shall be immediately brought to the Township's attention. The Township shall prescribe corrective repairs or rejection of the damaged items.

#### 4.08.02 Inspection Before Installation

All pipe and fittings shall be carefully examined for cracks and other defects while suspended above the trench immediately before installation in final position. Spigot ends shall be examined with particular care as this area is the most vulnerable to damage from handling. Defective pipe or fittings shall be laid aside for inspection by the Township, who will prescribe corrective repairs or rejection.

#### 4.08.03 Cleaning of Pipe and Fittings

All lumps, blisters, and excess coating shall be removed from the bell and spigot end of each pipe, and the outside of the spigot and the inside of the bell shall be wire brushed and wiped clean and dry and free from oil and grease before the pipe is laid.

#### 4.08.04 Laying of Pipe

All dirt or other foreign material shall be removed from the inside of the pipe before it is lowered into its position in the trench, and it shall be kept clean by approved means during and after laying. No tools or other articles shall be stored in the pipe at any time.

As each length of pipe is placed in the trench, the spigot end shall be centered in the bell and the pipe forced home and brought to correct line and grade. The pipe shall be secured in place with approved backfill material tamped under it except at the bells. Precautions shall be taken to prevent dirt from entering the joint space.

At times when pipe laying is not in progress, the open ends of the pipe shall be closed by a watertight plug or other means approved by the Township. This provision shall apply during the noon hour as well as overnight. If water is in the trench, the seal shall remain in place until the trench is pumped completely dry.

#### 4.08.05 Cutting of Pipe and Connections to Existing Water Mains

The Contractor shall cut the pipe in a straight and uniform manner, at right angles to the axis of the pipe, wherever necessary for placing valves, fittings, or closure pieces without damage to the pipe, and without extra cost to the Owner. The cut ends of the pipe shall be beveled before assembly of the joint.

The method of cutting pipe shall be subject to the approval of the Township.

Connection to existing mains shall be done at a time when it will least interfere with normal use of the main. The Contractor shall be responsible for draining water from the closed off section of the existing main so that the connection can be made.

The Contractor shall uncover existing mains at points of connection sufficiently in advance of making the connection to allow verification of the dimensions of the existing main and shall make any revisions required to the fitting, or obtain special

adaptors required for the connection. Existing pipe lines shall be adequately supported during the connection operation and prior to placement of backfill.

The Contractor shall be responsible for preventing contamination of existing water mains while the connection is made. He shall be responsible for any damage caused by his operations to existing mains to which the connections are being made.

4.08.06 Bell Ends to Face Direction of Laying

Pipe shall be laid with bell ends facing in the direction of laying, unless directed otherwise by the Township. Where pipe is laid on a grade of 10 percent or greater, the laying shall start at the bottom and shall proceed upward with the bell ends of the pipe upgrade.

4.08.07 Ductile/Cast Iron Sleeves

In connecting ductile/cast iron pipe together with a ductile/cast iron sleeve, the space between adjoining ductile/cast iron pipes shall not exceed two (2) inches. Where the space between adjoining ductile/cast iron pipe exceeds two (2) inches, a spacer shall be placed to fill the space. The spacer shall be a piece of ductile iron pipe of the same diameter and class as the adjoining pipe, and shall be cut straight and uniform and be free of defects and damage. In lieu of a spacer, the Contractor may elect to use Megalug joint restraining glands as manufactured by EBBA Iron, Inc. or approved equal on both sides of the sleeve. If Megalug restraining glands are used, the pipe shall extend into each end of the sleeve a minimum of one-third (1/3) the length of the sleeve, unless approved otherwise by the Township.

**4.09 JOINING OF MECHANICAL - JOINT PIPE**

4.09.01 General Requirements

The general requirements in Section 4.04 - 4.08 inclusive shall apply, except that where the terms "bell" and "spigot" are there used, they shall be considered to refer to the bell and spigot ends of the lengths of mechanical-joint pipe.

4.09.02 Cleaning and Assembly of Joint

The last eight (8) inches outside of the spigot and inside of the bell of mechanical- joint pipe shall be thoroughly cleaned to remove oil, grit, excess coating, and other foreign matter from the joint and then coated with a lubricant. The gasket lubricant shall be non-toxic, tasteless, and odorless, and shall be as supplied or recommended by the pipe manufacturer and approved by the Township. The Mega-lug restraint shall then be slipped on the spigot end of the pipe with the lip extension of the gland toward the socket, or bell, end. The rubber gasket shall be coated with lubricant and placed on the spigot end with the thick edge toward the Mega-lug.

#### 4.09.03 Bolting of Joint

The entire section of the pipe shall be pushed forward to seat the spigot end in the bell. The gasket shall then be pressed into place within the bell; care shall be taken to locate the gasket evenly around the entire joint. The Mega-lug restraint shall be moved along the pipe into position for bolting, all of the bolts inserted, and the nuts screwed up tightly with the fingers. All nuts shall be tightened with a suitable (preferably torque-limiting) wrench. The torque for various sizes of bolts shall be as follows:

<u>Nominal Joint Size</u> Inches	<u>Size</u> Inches	<u>Range of Torque</u> Foot - Pounds
3"	5/8	45 - 60
4" – 24"	3/4	75 - 90
30" – 36"	1	100 - 120
42" – 48"	1-1/4	120 - 150

Nuts spaced 180 degrees apart shall be tightened alternately in order to produce an equal pressure on all parts of the gland. When tightening bolts it is essential that the Mega-lug be brought up toward the pipe flange evenly, maintaining approximately the same distance between the gland and the face of the flange at all points around the socket. This may be done by partially tightening the bottom bolt first, then the top bolt, next the bolts at either side, and last, the remaining bolts. Repeat this cycle until all bolts are within the above range or torques. If effective sealing is not attained at the maximum torque indicated above, the joint should be disassembled and reassembled after thorough cleaning. Over stressing of bolts to compensate for poor installation practice is not allowed.

Bolts shall be high strength, low alloy Cor-Ten sheer bolts only conforming to ANSI/AWWA CIII/A21.11. Bolt manufacturer's certification of compliance must accompany each shipment.

#### 4.09.04 Permissible Deflection in Mechanical-Joint Pipe

Whenever it is desirable to deflect mechanical-joint pipe in order to form a long-radius curve, the amount of deflection shall not exceed the maximum limits shown in Table 1.



**TABLE 1**  
**PERMISSIBLE DEFLECTIONS IN MECHANICAL - JOINT PIPE**

Size of Pipe Inches	Max. Permissible Deflection Per Length - Inches				Approx. Radius of Curve Produced By Succession of Joints – Feet			
	12'	16'	18'	20'	12'	16'	18'	20'
3	21	28	31	35	85	110	125	140
4	21	28	31	35	85	110	125	140
6	18	24	27	30	100	130	145	160
8	13	18	20	22	130	170	195	220
10	13	18	20	22	130	170	195	220
12	13	18	20	22	130	170	195	220
14	9	12	13.5	15	190	250	285	320
16	9	12	13.5	15	190	250	285	320
18	7.5	10	11	12	230	300	340	380
20	7.5	10	11	12	230	300	340	380
24	6	8	9	10	300	400	450	500
30	6	8	9	10	300	400	450	500
36	5	7	8	9	330	440	500	550
42	5	6	7.5	8	340	450	510	570
48	5	6	7.5	8	340	450	510	570

**4.10 JOINING OF PUSH-ON JOINT PIPE**

4.10.01 General Requirements

The general requirements in Section 4.04 - 4.08 inclusive shall apply except that, where the terms "bell" and "spigot" are there used, they shall be considered to refer to the bell and spigot ends of the lengths of push-on joint pipe.

4.10.02 Cleaning and Assembly of Joint

The inside of the bell and the outside of the spigot end shall be thoroughly cleaned to remove oil, grit, excess coating, and other foreign matter. The circular rubber gasket shall be flexed inward and inserted in the gasket recess of the bell socket.

The thin film of gasket lubricant shall be applied to either the inside surface of the gasket or the spigot end of the pipe or both.

Gasket lubricant shall be non-toxic, tasteless, and odorless and shall be as supplied or recommended by the pipe manufacturer and approved by the Township.

The spigot end of the pipe shall be centered in the bell and forced or pushed home. Smaller sizes of pipe can be pushed or forced into place by hand; larger sizes will require the use of mechanical assistance.

The condition of the trench bottom must be such that correct location and position of the pipe to be joined is in a straight line assuring a joint of maximum tightness and permanent seal.

4.10.03 Permissible Deflection in Push-On Joint Pipe

Whenever it is desirable to deflect push-on joint pipe, in order to form a long radius curve, the amount of deflection shall not exceed the maximum limits shown in Table 2, unless recommended by the pipe manufacturer and approved by the Township.

TABLE 2  
PERMISSIBLE DEFLECTIONS IN PUSH-ON JOINT PIPE

Size of Pipe Inches	Max. Permissible Deflection Per Length - Inches				Approx. Radius of Curve Produced By Succession of Joints - Feet			
	12'	16'	18'	20'	12'	16'	18'	20'
3	12	16.5	19	21	140	185	205	230
4	12	16.5	19	21	140	185	205	230
6	12	16.5	19	21	140	185	205	230
8	12	16.5	19	21	140	185	205	230
10	12	16.5	19	21	140	185	205	230
12	12	16.5	19	21	140	185	205	230
14	7.5	10	11	12	230	305	340	380
16	7.5	10	11	12	230	305	340	380
18	7.5	10	11	12	230	305	340	380
20	7.5	10	11	12	230	305	340	380
24	7.5	10	11	12	230	305	340	380
30	7.5	10	11	12	230	305	340	380
36	7.5	10	11	12	230	305	340	380
42	5	6.5	7.5	8	340	460	510	570
48	5	6.5	7.5	8	340	460	510	570

4.10.04 Brass Wedges

Brass wedges are required for all push on joints.

## **4.11 SETTING OF VALVES AND FITTINGS**

### 4.11.01 General Requirements

Valves, fittings, plugs, and caps shall be set and joined to pipe in the manner specified above for cleaning, laying and joining pipe.

### 4.11.02 Location of Valves

Valves in water mains shall, where possible, be located as shown on plans unless otherwise directed by the Township.

### 4.11.03 Valve Boxes and Valve Pits

A valve box or a masonry pit shall be provided for every valve.

A valve box shall be provided for every valve that has no gearing or operating mechanism or in which the gearing or operating mechanism is fully protected with a cast-iron grease case. The valve box shall not transmit shock or stress to the valve and shall be centered and plumb over the wrench nut of the valve, with the box cover flush with the surface of the finished pavement or such other level as may be directed.

A masonry valve pit shall be provided for every valve that has exposed gearing or operating mechanisms. The valve nut shall be readily accessible for operation through the opening in the manhole, which shall be set flush with the surface of the finished pavement or such other level as may be specified. Pits shall be so constructed as to permit minor valve repairs and afford protection to the valve and pipe from impact where they pass through the pit walls.

### 4.11.04 Dead Ends

All dead ends on new mains shall be closed with ductile iron plugs or caps; such dead ends shall be equipped with suitable blowoff facilities.

## **4.12 SETTING OF HYDRANTS**

### 4.12.01 Location

Hydrants shall be located as shown or as directed so as to provide complete accessibility and minimize the possibility of damage from vehicles or injury to pedestrians. Maximum spacing between hydrants shall be five hundred (500) feet. Hydrants shall be located 6" inside the right-of-way, unless directed otherwise by Ottawa County Road Commission in developments.

When placed behind the curb, unless otherwise directed, the hydrant barrel shall be set so that no portion of the pumper or hose nozzle cap will be less than two (2) feet from the face of the curb.

When set in the lawn space between the curb and the sidewalk, or between the sidewalk and the property line, no portion of the hydrant or nozzle cap shall be within six (6) inches of the sidewalk.

4.12.02 Position

All hydrants shall stand plumb and shall have their nozzles parallel with, or at right angles to, the curb, with the pumper nozzle facing the curb, except that hydrants having two hose nozzles 90 degrees apart shall be set with each nozzle facing the curb at an angle of 45 degrees. Hydrants shall be set to the established grade, with nozzles a minimum of twenty seven (27) inches above the street centerline grade and a minimum of twenty one (21) inches above the ground at the hydrant, unless otherwise directed by the Township.

4.12.03 Connection to Main

Each hydrant shall be connected to the main with a six (6) inch ductile iron branch controlled by an independent 6 inch gate valve, unless otherwise specified. All hydrant gate valves shall be open at the time of testing and remain open thereafter. The cost of the branch pipe shall be incidental to cost of installing the hydrant.

4.12.04 Hydrant Drainage

All hydrant drains and weep holes shall be plugged unless otherwise directed by the Township.

4.12.05 Pumping of Hydrants

All hydrants shall be pumped completely dry when the water main is placed in service.

**4.13 ANCHORAGE**

4.13.01 Restrained Joint Pipe

The use of restrained joint pipe shall be first approved by the Township. If approved, all ductile iron restrained joint pipe shall be Clow Corporation "Super-Lock"; American Ductile Iron Pipe "Lok-Ring Joint" or Flex-Ring Joint; Griffen Pipe Products Co. "Snap-Lok"; or approved equal. All components of the restrained joint shall be as manufactured, supplied, or recommended by the manufacturer of the restrained joint pipe system actually installed. The Township will first encourage the use of EBAA Iron Sales Megalug or approved equal to restrain pipe.

4.13.02 Joint Restraining Glands

Joint restraining glands shall be Megalug as manufactured by EBAA Iron Sales, Inc. or approved equal.

4.13.03 Mechanical Joint Anchoring Fittings

Mechanical joint anchoring fittings shall be as manufactured by Clow Corporation, Tyler Corporation, or approved equal.

4.13.04 Anchorage for Hydrants

All hydrants shall be restrained to the hydrant lateral valve, and the hydrant lateral valve shall be restrained to the main using an approved joint restraint system consisting of restrained joint pipe, joint restraining glands (Megalug), mechanical joint anchor fittings, or approved equal.

Bolts shall be high strength, low alloy Cor-Ten shear bolts only conforming to ANSI/AWWA CIII/A21.11. Bolt manufacturer's certification of compliance must accompany each shipment.

4.13.05 Anchorage for Plugs, Caps, Tees, Bends and Valves

Unless otherwise specified or approved by the Township, movement of all plugs, caps, tees, bends, and valves shall be prevented by use of restrained joint pipe or joint Megalugs as manufactured by EBAA Iron Sales.

Bolts shall be high strength, low alloy Cor-Ten shear bolts only conforming to ANSI/AWWA CIII/A21.11. Bolt manufacturer's certification of compliance must accompany each shipment.

When joints are to be restrained with mechanical devices as noted above, all joints shall be restrained for a minimum distance from the fitting as required in the following table.

PIPE RESTRAINT LENGTH REQUIRED, FEET

Pipe Diameter	Tees, 90° Bends	45° Bends	22-1/2° Bends	11-1/4° Bends	Dead Ends	Reducers (one size)	**
4"	23	9	5	2	57		
6"	32	13	6	3	82	43	63
8"	41	17	8	4	104	43	55
12"	58	24	12	6	149	80	120
16"	74	31	15	7	192	82	110
20"	89	37	18	9	233	82	104
24"	104	43	21	10	272	82	99
30"	123	51	25	12	328	115	148
36"	141	58	28	14	379	115	140

\*\*If straight run of pipe on small side of reducer exceeds this value, then no restrained joints are necessary.

NOTE: The length of restrained joint pipe required as shown in the table above is based on trench backfill being compacted to 95% of maximum unit weight in accordance with MDOT procedures. If the pipe is wrapped in polyethylene, a greater length of restrained pipe will be required as specified, shown on the Plans, or directed by the Township. A multiplier of 1.43 shall be used if the pipe is installed with polyethylene wrap.

All joints lying within the above minimum distances from the fitting must be restrained as noted herein.

Tees: Tees shall be restrained in the branch direction as required in the table above. Also, to augment the above, in the straight through direction, the minimum length of the first pipe on either side of the tee shall be ten (10) feet. In those cases where a valve is placed at the tee, the valve shall be restrained to the tee as noted below, and the next pipe shall be a minimum length of ten (10) feet.

Plugs/Caps: All dead ends on water mains shall be plugged or capped with standard plugs or caps. The water main, including the plug or cap shall be restrained back from the plug or cap as required in the table above.

Bends: Bends shall be restrained in both directions as required in the table above.

Valves: Valves used in conjunction with restrained joint pipe shall be restrained in accordance with the recommendations of the manufacturer of the restrained joint pipe. All valves at crosses or tees shall be restrained to the tee by use of restrained joint pipe or joint restraining glands as specified above. Hydrant valves may be restrained using mechanical joint anchoring fittings.

#### 4.13.06 Reaction Backing (Thrust Blocks)

Reaction backing (thrust blocks) shall be used only at locations indicated on the Plans, or approved by the Township.

## REACTION BACKING

Minimum Bearing Area against an undisturbed trench wall, in square feet, for sand is indicated in the table below. Details of placement are shown in Standard Details.

Pipe Size	Tees, Plugs, Wyes,		Wyes, 22-1/2° Els or Less
	45° Els	Hydrants, 90° Els	
6"	3	3	1
8"	4	6	2
10"	7	9	3
12"	9	11	3
16"	13	20	6
20"	20	28	8
24"	28	40	11

### Other Soil Conditions

Cement Sand or Hardpan	-	multiply above by 0.5
Gravel	-	multiply above by 0.7
Hard Dry Clay	-	multiply above by 0.7
Soft Clay	-	multiply above by 2.0

Muck-secure all fittings with restrained joint pipe or joint restraining glands, with concrete reaction backing the same as listed for sand conditions.

## **4.14 HYDROSTATIC TEST**

### 4.14.01 Procedure

All tests will be made by the Contractor using his own equipment, operators, and supervision, in the presence of the Township or his duly authorized representative. The length of the section to be tested shall be as approved by the Township. The test shall not be against an existing valve, unless written permission is obtained from the water system operator. In no case shall a test be made against an existing valve that is found to be leaking or otherwise defective.

### 4.14.02 Air Removal Before Test

Before applying the specified test pressure, all air shall be expelled from the pipe. If permanent air vents are not located at all high points, the Contractor shall install corporation cocks at such points so the air can be expelled as the line is filled with water. After all the air has been expelled, the corporation cocks shall be closed and the test pressure applied.

#### 4.14.03 Leakage Test

A leakage test shall be conducted in the presence of the Township after the pressure test has been satisfactorily completed. The Contractor shall furnish the pump, pipe, connections, gages and all other necessary apparatus, and shall furnish the necessary assistance to conduct the test. The duration of the test shall be two (2) hours, and during the test the main shall be subjected to a pressure of 150 psi.

Leakage shall be defined as the quantity of water that must be supplied into the newly laid pipe, or any valved section thereof, to maintain the specified leakage test pressure after the air in the pipeline has been expelled, and the pipe has been filled with water. When several valved sections are tested as one test, the maximum allowable leakage will be equivalent to the calculated smallest value of the maximum allowable leakage for any valved section. No pipe installation will be accepted if the leakage is greater than that determined by the formula:

$$L = \frac{SD\sqrt{P}}{148,000}$$

Where:

L = Allowable leakage in gallons per hour

S = Length of pipe tested, in feet

D = Nominal diameter of the pipe, in inches

P = Average test pressure during the leakage test, in pounds per square inch gage.

This formula is based on allowable leakage of 10.49 gallons per day, per mile of pipe, per inch of nominal diameter at 150 psi.

The Township shall be furnished a written report of the results of the leakage test that identifies the specific length of pipe tested, the pressure, the duration of the test, and the amount of leakage. The report shall be signed by the Contractor and the Township.

#### 4.14.04 Variation from Permissible Leakage

If any test of pipe laid discloses leakage greater than that specified above, the Contractor shall at his own expense locate and repair the leaks until the leakage is within the specified allowance.

#### 4.14.05 Time for Making Test

The pipe may be subject to hydrostatic pressure and inspected and tested for leakage at any convenient time after the trench has been partially backfilled. Where any section



of the main is provided with concrete reaction backing, the hydrostatic pressure test shall not be made until at least five (5) days have elapsed after the concrete reaction backing was installed. If high-early-strength cement is used in the concrete reaction backing, the hydrostatic pressure test will not be made until at least two (2) days have elapsed.

#### **4.15 CLEANING AND DISINFECTION**

##### **4.15.01 Flushing Water Main**

The water main and services three (3) inches in diameter and larger shall be flushed by providing taps in sufficient size or number to provide a velocity as required by AWWA Standard C651. Hydrants may be used providing the requirements listed below are met.

##### **4.15.01.01 Procedure**

The Contractor shall submit to the Township a procedure schedule outlining the method he proposes to use for flushing water mains. Mains shall be flushed at a maximum of 1/4-mile intervals.

##### **4.15.01.02 Time for Flushing**

Flushing may be done prior to pressure testing or following pressure testing but, in any case, prior to chlorination of the water main.

##### **4.15.02 Chlorination**

All newly-laid lines shall be chlorinated. The Contractor shall furnish all necessary equipment and materials and shall furnish all necessary assistance for effective disinfection of the water mains. Chlorination shall be accomplished by using the following general procedure.

##### **4.15.02.01 Procedure**

After the water main has been pressure tested and flushed, the Contractor shall pump a chlorine solution into the water main in such a manner and at such strength that the residual free chlorine shall be 50 to 100 ppm.

The amount of chlorine required for each 100 feet of pipe of various diameters to produce 50 ppm chlorine solution is as follows:

<u>Pipe Sizes (Inches)</u>	<u>100 Percent Chlorine (lb.)</u>	<u>16% Bleach (gal.)</u>
6	.061	.046
8	.108	.081
10	.170	.128
12	.240	.180
16	.436	.313
24	.980	.737
30	1.463	1.100

4.15.02.02 High Test Calcium Hypochlorite

("HTH", Perchlolen", Pittchlor"). Prepare a ten-thousand-parts-per-million solution in water and pump at a constant rate into the water main while bleeding off the water at the extreme end. The bleed rate will determine the feed rate of the chlorine in order to arrive at a 50 to 100 ppm solution in the water main.

4.15.02.03 Liquid Chlorine

Liquid Chlorine may be applied to the water main much the same way as the hypochlorite solution listed above. The rate of application will have to be adjusted for the degree of concentration of the liquid chlorine.

4.15.02.04 Point of Application

The chlorinating agent shall be applied at the supply end of the line through a corporation cock. The water for injecting the chlorine into the new main may be taken from the pressure side of the isolation valve or by utilizing a pressure pump.

Care shall be exercised to prevent any of the strong chlorine solution from entering existing water mains.

4.15.02.05 Retention Period

The chlorinated water shall be retained in the new water main for a period not to exceed 24 hours nor less than 16 hours in the event 50 parts per million is used. In cases where a shorter retention period is necessary, a stronger solution may be used and the retention period reduced accordingly. For these stronger solutions the approval of the Township must be secured in writing as to the length of retention time in relationship to chlorine strength.

While the chlorine solution is in the line, the Contractor upon approval from the Township shall operate valves and hydrants in the chlorinated section to insure the complete disinfection thereof.

#### 4.15.02.06 Flushing and Testing

The chlorinated water shall be flushed from the main at the end of the retention time so that the entire line is clear of any residual chlorine. A sample shall be taken from the line (through a corporation stop) after the line is flushed, and delivered to the Township for bacteriological analysis. In the event that the water does not pass this bacteriological test, the chlorination procedure outlined above shall be repeated until the quality of water is substantially the same as that being delivered from the existing distribution system. The test procedure shall be repeated until two (2) consecutive safe results are obtained at each location as required by the Michigan Department Environmental Quality. The two samples shall be taken 24 hours apart. Flushing of the main shall not occur between the two samples.

#### **4.16 DEAD ENDS/LOOPING**

Generally the Township will not permit dead end watermain and will require looping.

#### **4.17 SHUT DOWNS OF EXISTING WATERMAIN FOR CONNECTION**

1. Shut downs of existing watermains can only be made when approved by and coordinated with the Township.
2. Notice to water customers affected by the shut down shall be given by the Township.
3. The duration of the shut down shall be minimized. All necessary labor, equipment and materials must be present before work proceeds.
4. The Township shall be present, perform the shut down and inspect the connection.

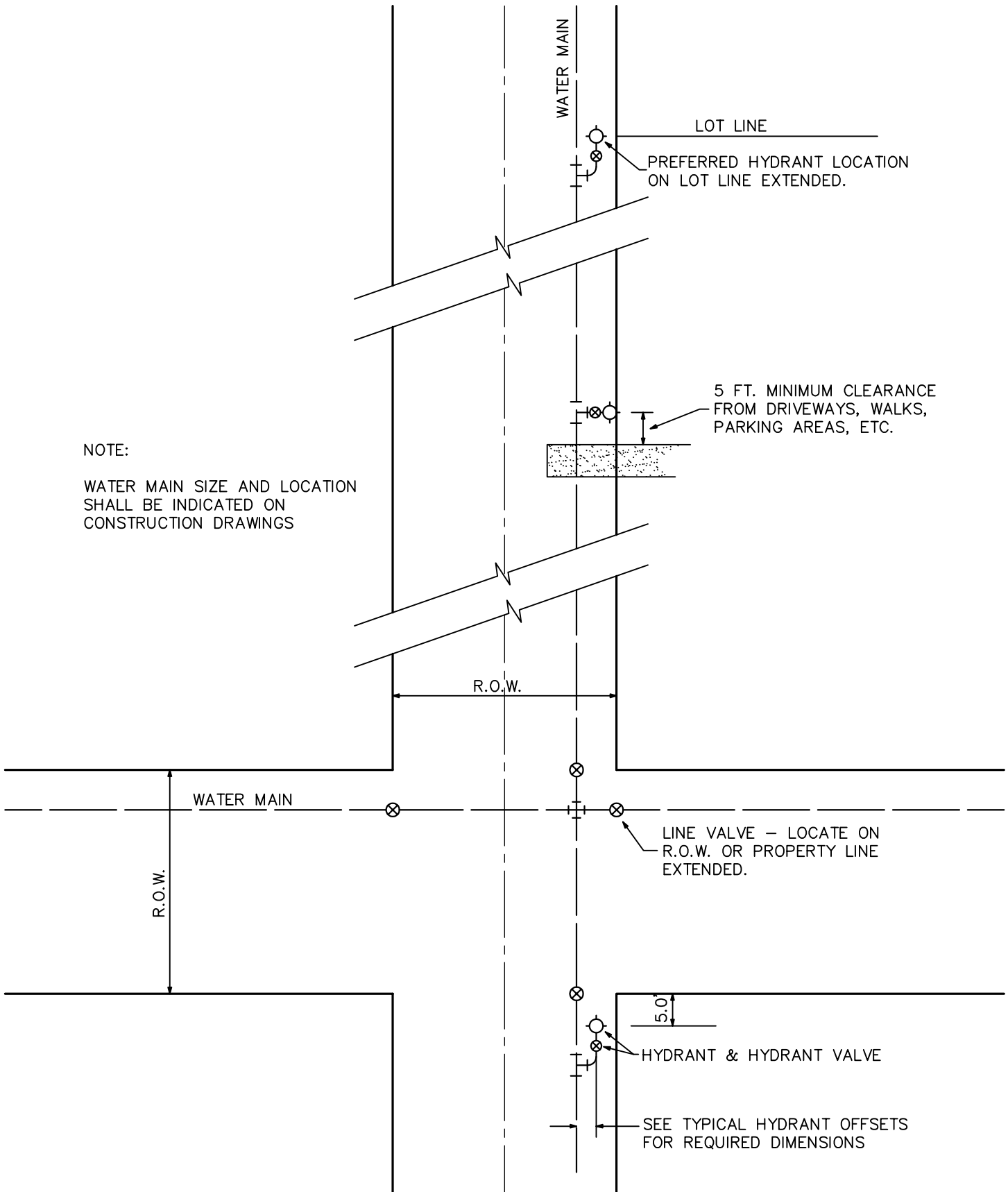

## VALVE & HYDRANT LOCATIONS

PREIN & NEWHOF  
CONSULTING ENGINEERS

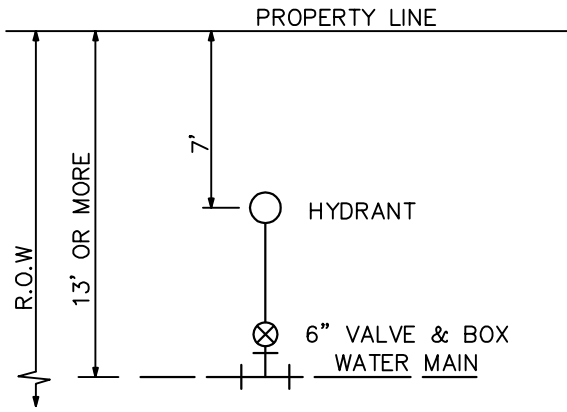

A. WATER MAIN MORE THAN 13' FROM PL  
HYDRANT LOCATED AT 7' FROM PL  
(WHEN REQUIRED BY O.C.R.C.)

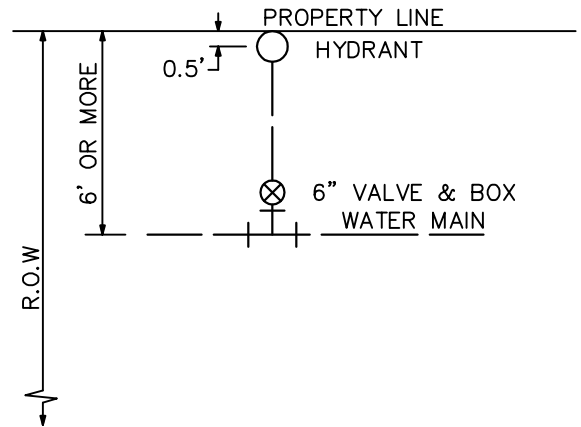

B. WATER MAIN MORE THAN 6' FROM PL  
HYDRANT LOCATED AT 0.5' FROM PL

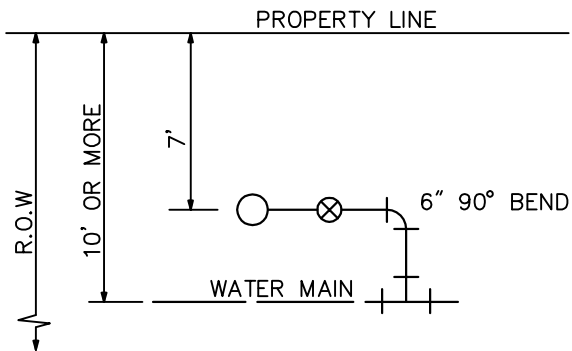

C. WATER MAIN MORE THAN 10' FROM PL  
HYDRANT LOCATED AT 7' FROM PL  
(WHEN REQUIRED BY O.C.R.C.)

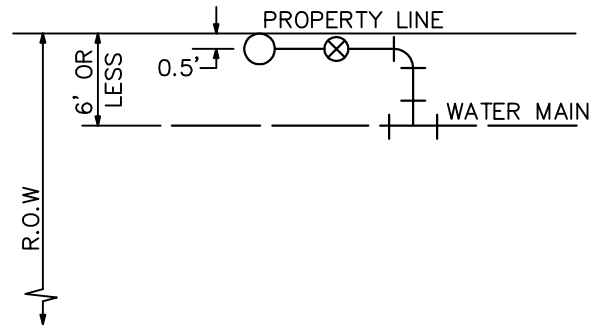

D. WATER MAIN LESS THAN 6' FROM PL  
HYDRANT LOCATED AT 0.5' FROM PL

## HYDRANT OFFSETS

PREIN & NEWHOF  
CONSULTING ENGINEERS

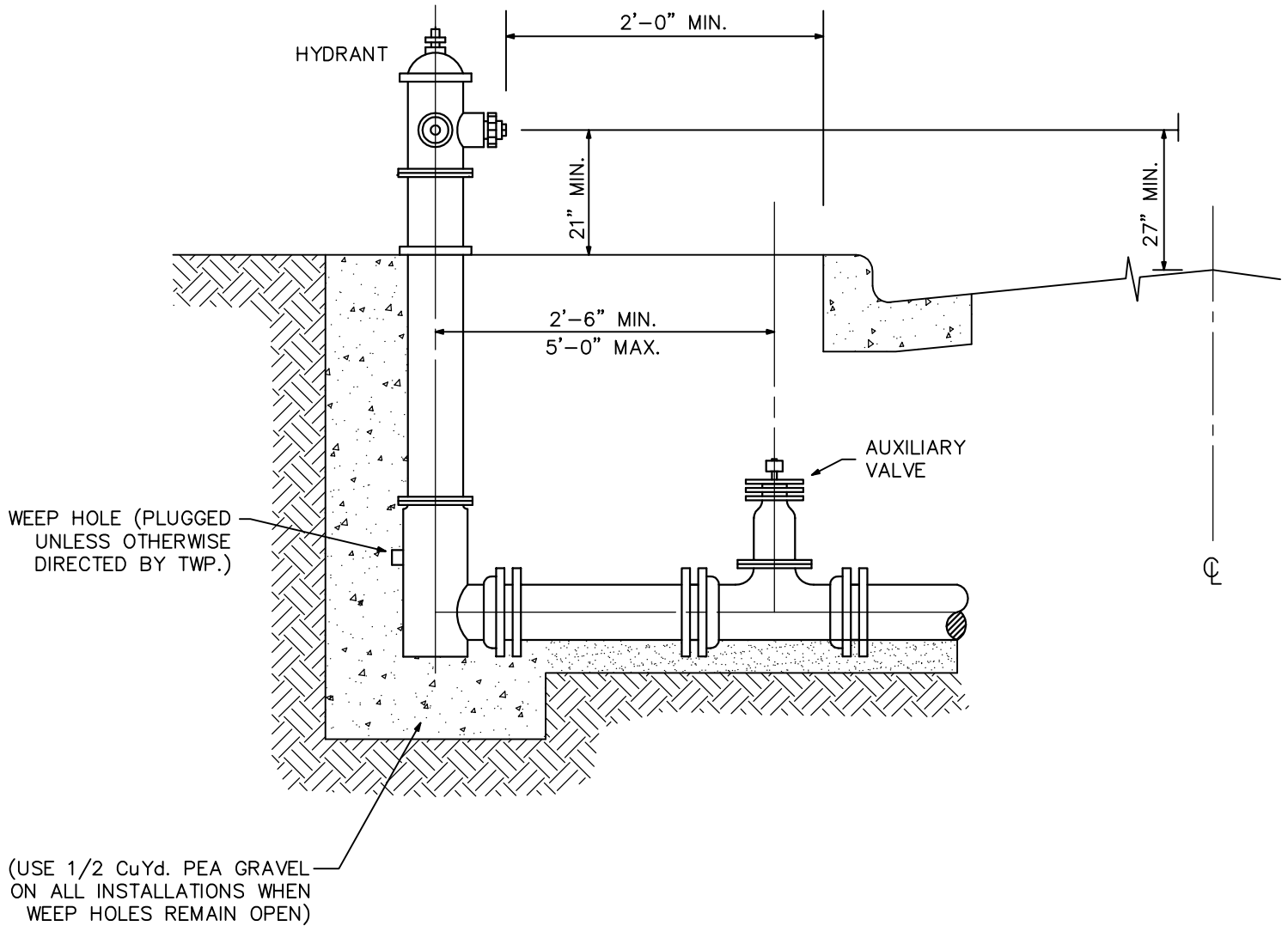

## HYDRANT DETAIL

PREIN & NEWHOF  
CONSULTING ENGINEERS

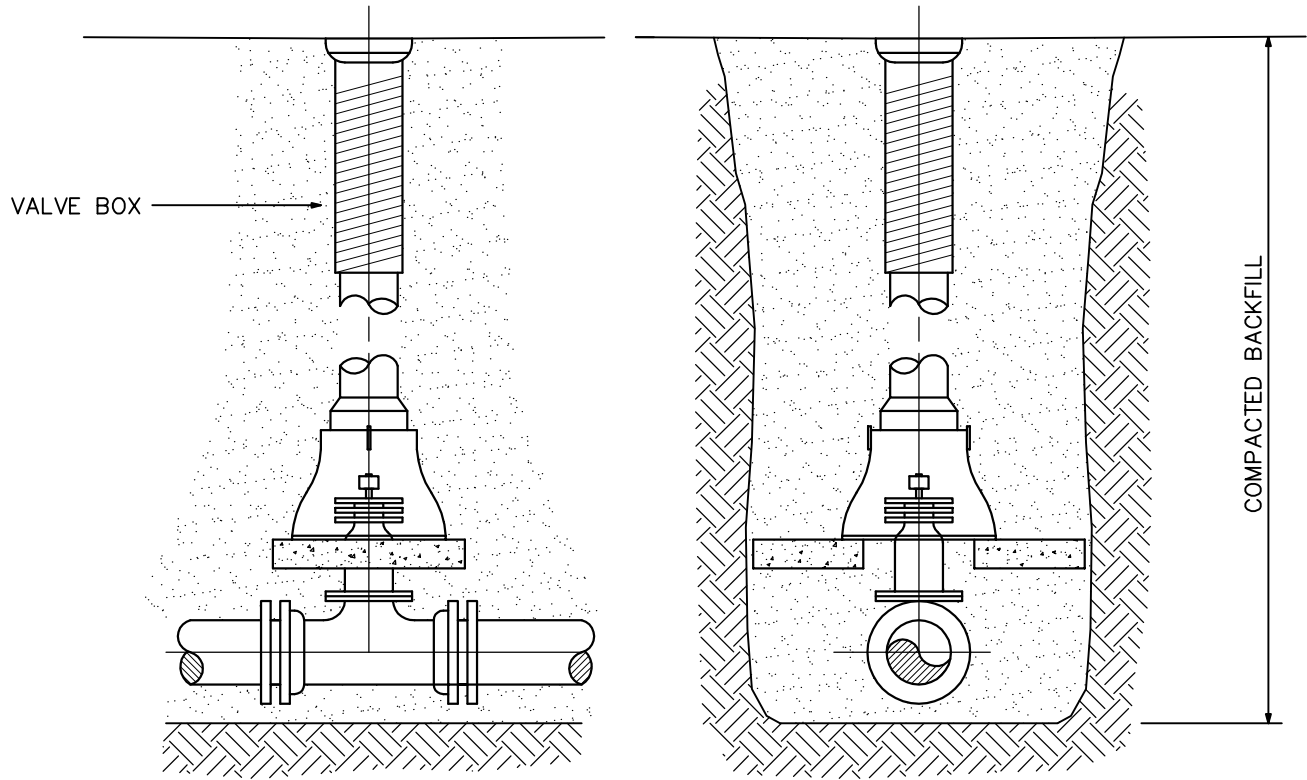

SIDE VIEW

FRONT VIEW

NOTE:  
 VALVE BOX AND SUPPORTS SHALL  
 NOT BE IN CONTACT WITH VALVE  
 OR PIPE. MAINTAIN MINIMUM  
 2" CLEARANCE

## VALVE & BOX FOUNDATION

PREIN & NEWHOF  
 CONSULTING ENGINEERS

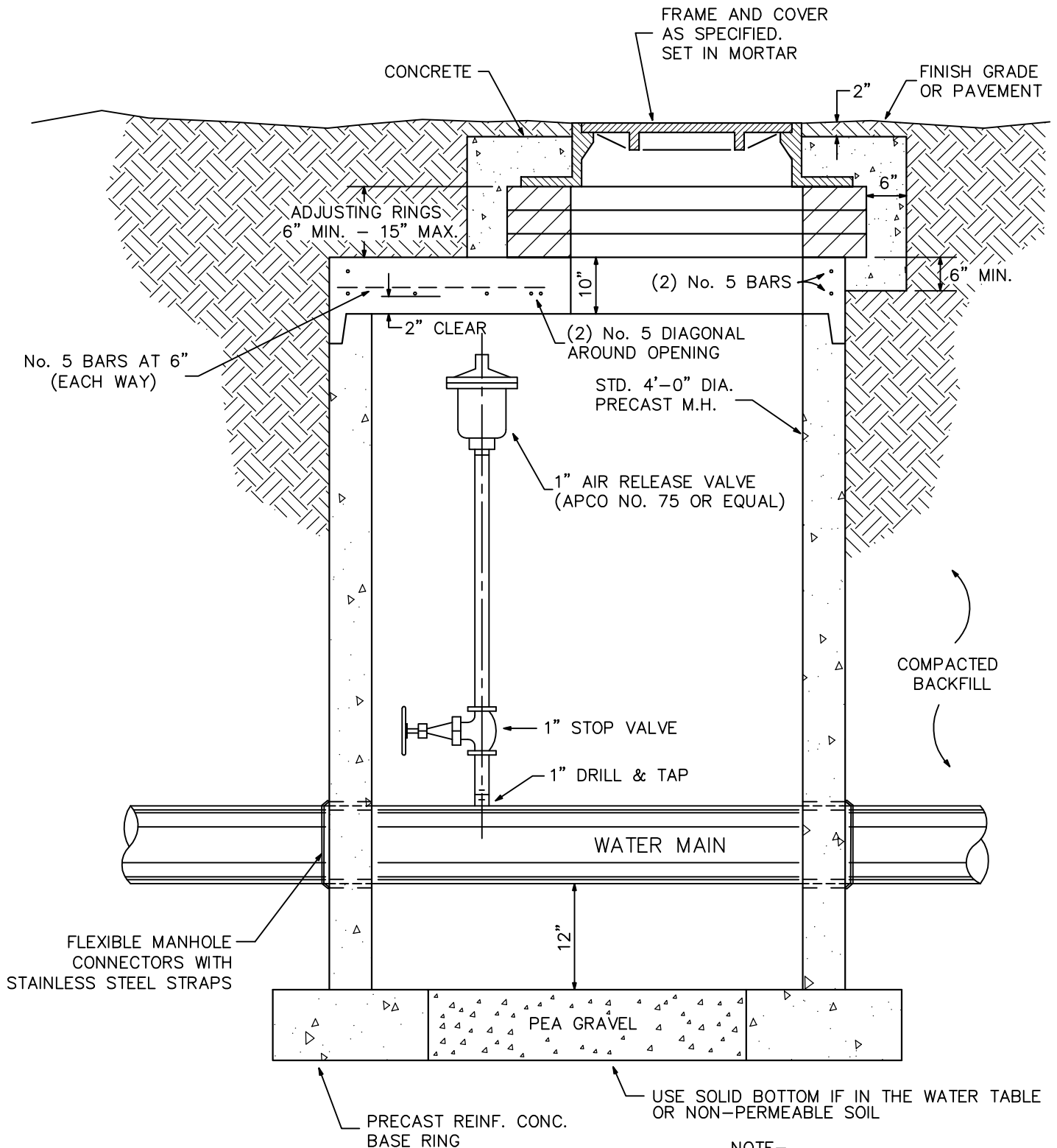

NOTE—  
INSTALL AIR RELEASE VALVE AT  
THE VERY HIGHEST ELEVATION  
OF THE WATER MAIN.

## STANDARD AIR RELEASE VALVE — MANHOLE

PREIN & NEWHOF  
CONSULTING ENGINEERS



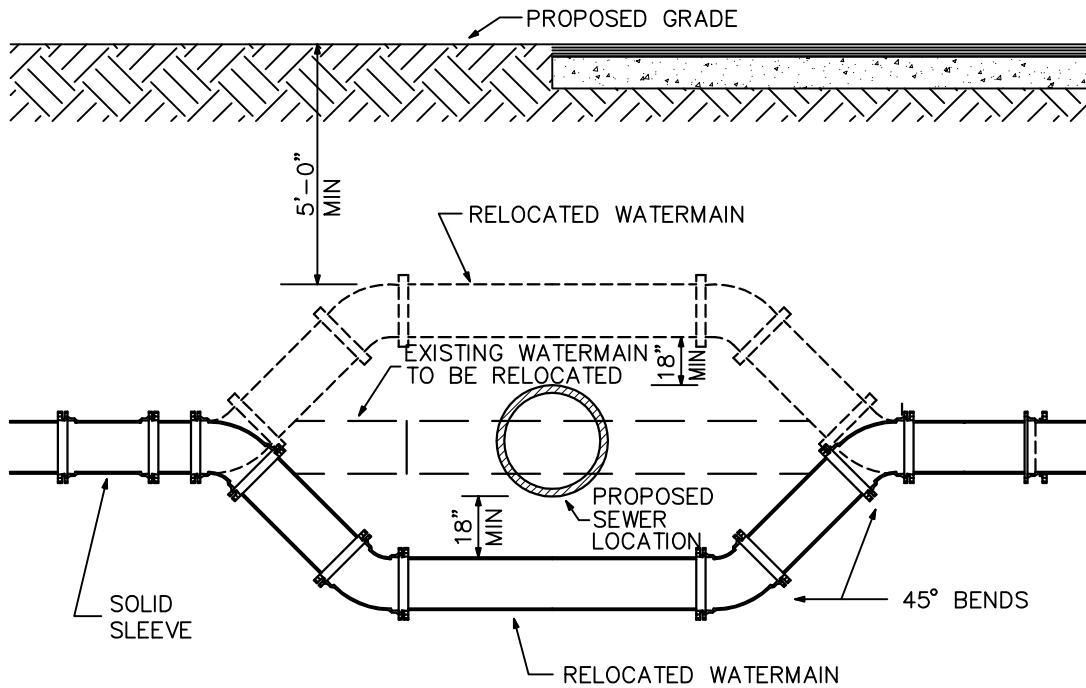

NOTE:

WHEN THE MINIMUM CLEARANCE AND COVER CAN BE OBTAINED, THE WATERMAIN IS TO BE RELOCATED ABOVE THE SEWER, UNLESS IT CREATES A HIGH POINT IN 12" W.M. OR LARGER.

## WATERMAIN RELOCATION DETAIL

PREIN & NEWHOF  
CONSULTING ENGINEERS